

Tefute[®]

Stone Coated Steel Roofing Tiles

Installation Manual

For **Roman & Roman II** Profiles

This page intentionally left blank

Introduction

This installation manual is intended only as a guide for the proper installation of the Tefute stone coated tile roofing systems for the Classical, Bond, Shingle and Wood-shake profiles. The materials and methods described in this manual help preserve the overall integrity and longevity of the roofing system. In addition, these instructions should be followed as closely as possible and installed according to manufacturer specifications to maintain the coverage of the manufacturers limited warranty. This installation manual is not intended to address all aspects of a roofing installation; a quality installation is dependent upon the workmanship of the roofing contractor. Roof shapes can vary greatly and each installation is different but the general steps and installation process will be universal.

Safety

Please adhere to all recommended safe roofing practices. Wear appropriate clothing and use safety equipment such as harnesses, protective eyewear and soft-soled shoes. Use proper tools and keep the roof clear of debris. Keep a proper lookout for power cords and roof line to avoid falling. It is recommended to use strong and stable scaffolding in lieu of ladders.

Codes and Requirements

Building codes vary. Consult your local building codes. Tefute Stone Coated Steel Tiles conform to International Building Code (IBC) and International Residential Code (IRC) and the Los Angeles Department of Building and Safety (LADBS). Tefute Stone Coated Steel Tiles have been evaluated by ICC-ES for thermal and moisture protection, fire resistance, wind-uplift resistance and weather resistance. Tefute Stone Coated Steel Tiles are considered Class A roof assemblies when installed properly to manufacturer specifications. Tefute Building Materials, LLC and its partners or subsidiaries is not responsible for misinstallations, roofing installations not meeting local building codes and other roofing complications not covered in this installation manual. Failure to adhere to proper installation guidelines or local building codes may void your manufacturers limited warranty.

Minimum 4/12 roof pitch or 12 Degree slope

Deck preparation

The deck must be cleaned, level and square for proper installation. Fire retardant plywood is NOT an approved decking substrate. It is recommended to remove existing roofing materials down to the deck prior to the installation of Tefute Stone Coated Steel Tiles. Failure to do so may void your manufacturers warranty and/or violate your local building codes. Ensure all nails are hammered down and replace any damaged areas.

Must be compliant with local Building Codes, but it should be less than # 8 x 2-3/8" long ring shank nails spaced 6"o.c. In reroofing, where the deck is less than 19/32" thick (Minimum 15/32").

Underlayment

One layer of #30 underlayment or 2 layers of #15 underlayment is the minimum underlayment requirement for all roofing installations. Underlayment is important and can extend the overall life expectancy and performance of your Tefute Roofing System. There are many excellent roofing underlayment products readily available, as we do not endorse any single product, a membrane based underlayment, such as ice and water shield (#90) or single ply membrane is recommended especially in freezing climates.

The requirements for the underlayment should be an ASTM D 226 Type II installed with a minimum 4" side-lap and 6" end-laps. The underlayment should be fastened with corrosion resistant tin-caps and 12 gauge 1 1/4" annular ring-shank nails, spaced 6"o.c. at all laps and two staggered rows 12"o.c. in the field of the roll. Valleys ,Ridge & Hip , must have one layer of Type 30 felt underlayment, 36" wide or ice and water shield underneath as required by local building codes and/or NOA.

Batten

Install 2" x 2" nominal size battens in standard grade lumber using a 16d minimum common nail at 18" to 24" on center into rafters. **Within the 30" of the outer edges of the perimeter and corner on the roofing frame, install each nail 10" on center into rafters.** Install 2" x 2" 's at hips, The spacing on the Batten will be determined by the panel profile. The spacing measurements for Battens starts at the front of the batten following the next Batten as you go up the roof.

Counter Battens and Battens: When installing over an irregular surface, use counter Battens or skip/spaced sheathing. Place the 1" x 4" counter battens and position over the framing members 18" to 24" on center and secure the area by using a 16d common nail or equivalent into rafters or through sheathing 7" on center.

Fasteners

Field condition: Panels must be fastened to the battens with approved # 8 x 1 ½” long screws and bonded washer driven into the (lower) butt edges course and upper edge of adjoining lower course spaced 12”o.c. Use 6 approved screws for each full panel.

Perimeter and corner: Panels fastened to battens with approved # 8 x 1 ½” long hex head screws # 8 x 1 ½” long screws and bonded washer driven into the (lower) butt edges course and upper edge of adjoining lower course spaced 7”o.c. 11 approved screws for each full panel.

Cutting Panels

Do not cut panels on the roof. Metal shavings and residue may cause damage or injury. Measure on the roof and make cuts on the ground in a protected area. Tefute Stone Coated Steel Tiles are manufactured from corrosion resistant aluminum-zinc alloy coated steel with a protective coating of stone granules to add to the beauty and aesthetics. Panels may be cut with a table saw or circular saw with concrete or metal cutting blade. Tin snips may be used for finer cuts. Leftover panels may be custom cut to size for finishing pieces.

Not compatible with COPPER or LEAD

Do NOT use pressure treated or fire-retardant lumber

Installation Tools

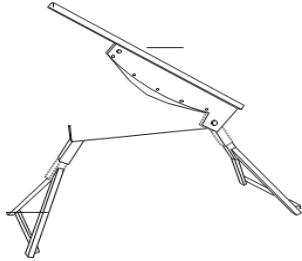

Cutter

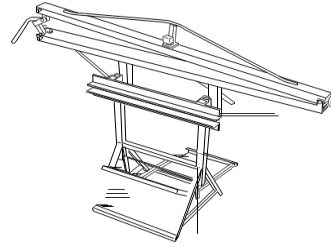

Bender



Measuring Tape



Crayon Marker



Snips



Roofing Grade Polyurethane Sealant

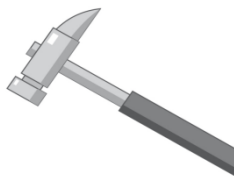

Hammer



Screw Gun



**#9 Hex 1/4" Diameter x 1-1/2" Long
Screws**

Stone Coated Steel Tile Profiles

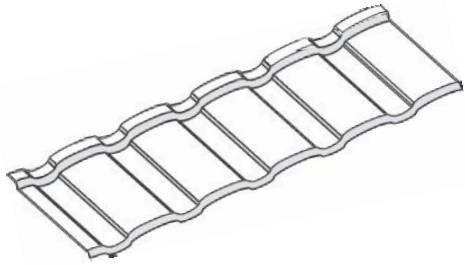

Roman Tile

51-1/8" × 16-3/8"

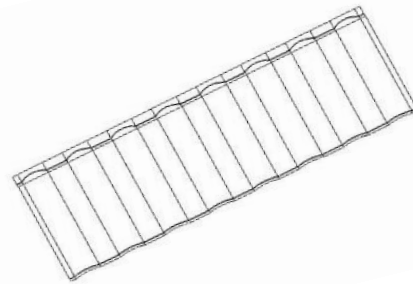

Roman II Tile

52-3/8" × 16-5/8"

Accessories

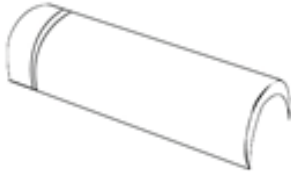

Circular Ridge & Hip
16" × 6"

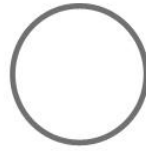

Round seal
6" Diameter



Bird Stop
51-1/8" of Length



Bird Stop Top
51-1/8" of Length

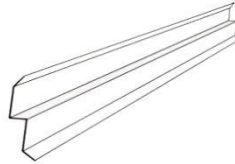

Side Flashing
78-3/4" × 1-3/4" × 3/4" × 1-3/4"



Fascia/Eave Flashing
78-3/4" × 2" × 3-1/2" × 3/8"

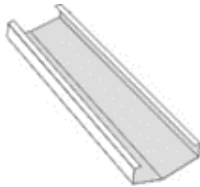

Valley
78-3/4" × 7"



Screws
#8 Hex 1/4" Diameter
x 1-1/2" Long

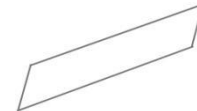

Flat-Stock Sheets
47-1/4" × 17-3/4"

Note: Factory accessories are not required with Tefute Stone Coated Roofing Tiles. Generic accessories and roofing components may be purchased locally. However, accessories are important to the overall longevity and performance of your Tefute Stone Coated Roofing System and help to integrate all of the roofing components to ensure a lasting top of class roof. Accessories are stone coated and color matched for a beautiful and finished look. Screws are painted to match roof color.

Component and Accessory Placement

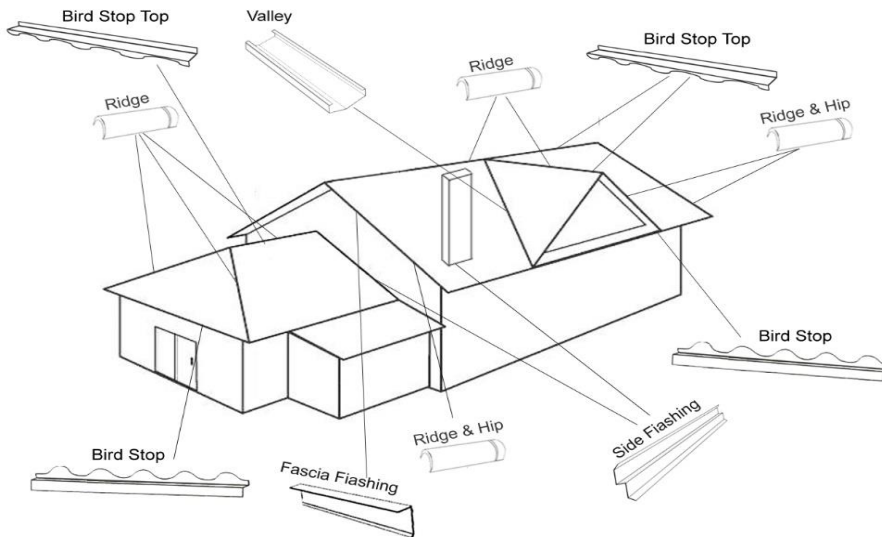

This picture above shows the correct position for each component and accessory.



Required

Appropriate underlayment and batten system required prior to metal tile installation as pictured above.

NOTE: All roofs vary in size and shape, proper installation is based on each individual scenario and proper installation processes is at the roofing contractor’s discretion.

Batten System Installation

Batten system can be installed using wood, plastic or metal. For this installation manual, we recommend a wood batten system. Consult your roofing contractor for plastic or metal battens.

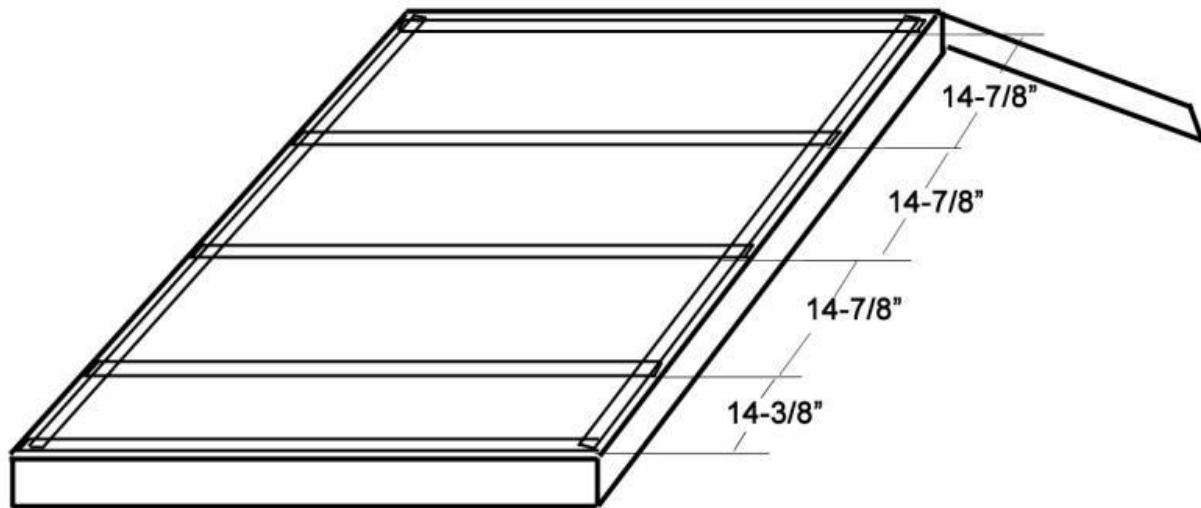

The batten system should be attached to the roof deck above the underlayment prior to installing Tefute Stone Coated Steel Tiles. The batten system should be well secured using 16d minimum common nail at 18" to 24" on center into rafters. **Within the 30" of the outer edges of the perimeter and corner on the roofing frame, install each nail 10" on center into rafters.** To ensure consistent distance between the battens make a 14-3/8" and 14-7/8" spacer. Place the first 2x2 batten parallel to the fascia from the lower bottom to the top and use the spacer to space out 14-3/8" from the fascia. Each batten after the first should be installed in a parallel manner and using the spacer be placed 14-7/8" apart. All battens should be equal in distance and parallel to each other.

Batten Installation for Valleys, Ridges & Hips

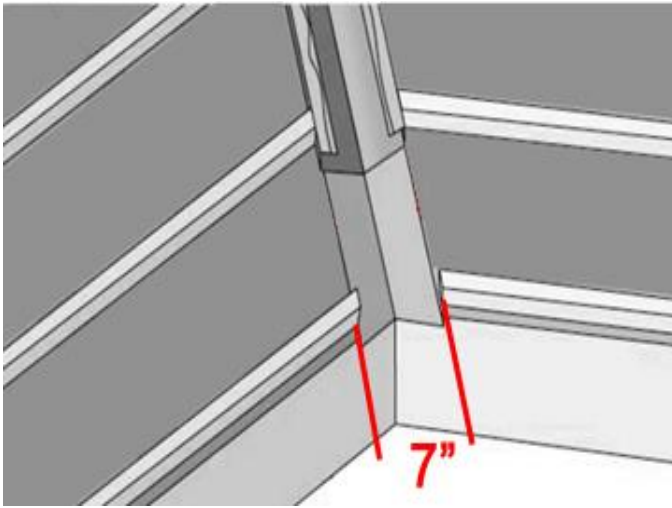

Installation for Valleys:

The batten for the valley should have a 7” gap between the two portrait direction battens.

In new construction applications, it’s required for the metal valley flashing to have one layer of Type 30 felt underlayment, 36” wide or ice and water shield underneath as required by local building codes.

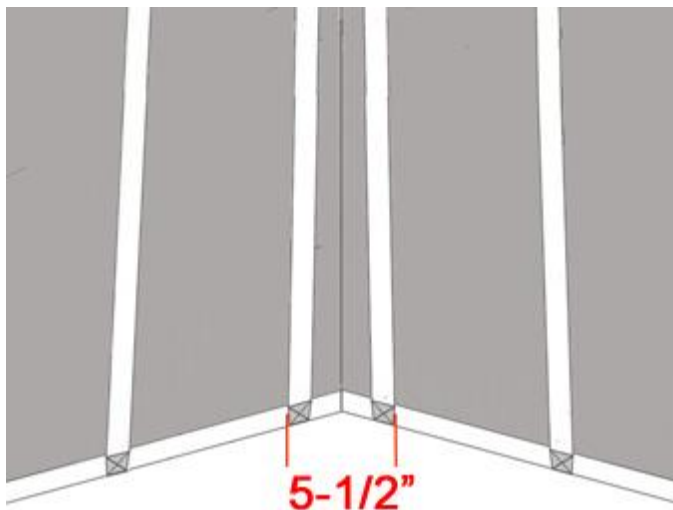

Installation for Ridges:

The batten for the ridge should have a 5-1/2” gap between the last two landscape battens on the ridge.

Tile and Shake panels require the same steps. Measure from the front of the back flange to the front of the 2 x 2 at the ridge. This will be the bend line. Bend the panel at the bend line. Add 2” to the bend line and cut the panel.

Batten Installation for Hips

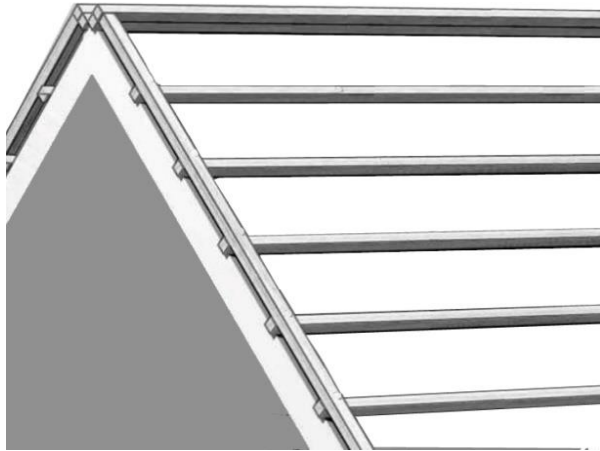

The batten for the Hips should be placed on the edge of the roof and fastened to the batten.

When installing Tile, run a 2" x 2" above the battens, next to the hip. Bring the panel to the 2" x 2" and turn the panel up 2". Measurements for hip cuts are made the same as valleys cuts. After cutting the panels, make a 2" bend that will run along the 2" x 2" located at the hip.

Flashing Installation

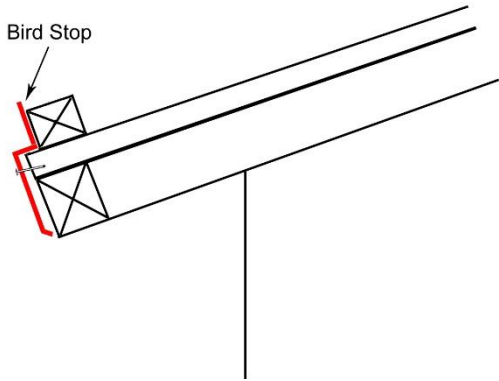

Bird Stop:

The Bird Stop (pictured in red) should be placed on the batten facing the front edge of the house and should cover the batten and act as a metal drip edge at the front facing hip.

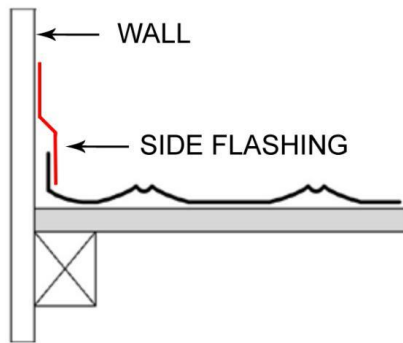

Side Flashing:

Use side flashing (pictured in red) to seal roof to wall junctions.

Tile panels (pictured in black) connect to the wall and should be bent up 1-1/2" using a bender and the folded edge flattened, press tight to wall sealing top and bottom edges with polyurethane sealant. Cover the bent part of the tile panel with the side flashing as pictured. Use polyurethane sealant to seal the top and bottom edge of the side flashing and fasten it to the wall with fasteners every 12".

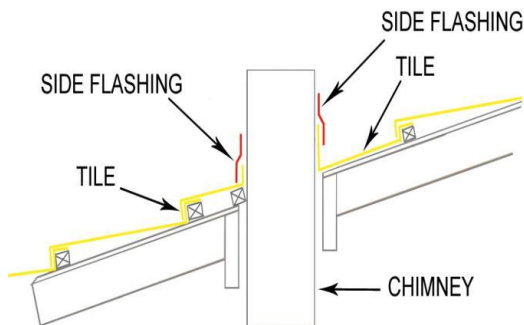

Chimney Flashing:

Use side flashing (pictured in red) to seal around chimney.

Each side of tile panels (pictured in yellow) connect to the chimney and should be bent up 1-1/2" using a bender and the folded edge flattened, press tight to chimney wall sealing top and bottom edges with polyurethane sealant. Place side flashing on front and back sides of chimney. Cover the bent part of the tile panel with the side flashing as pictured. Use polyurethane sealant to seal the top and bottom edge of the side flashing and fasten it to the chimney with fasteners every 12".

Valley Installation

Open Valley: To create an open valley, be sure to snap lines to the desired opening. Begin working on one side of the valley at a time, measure, cut and bend panels starting at the bottom of the valley and working up.

Closed Valley: Locate and establish the center of the valley by either snapping a line or following existing center rib. After valley flashing has been fit correctly and secured into the valley area, being by starting on one side of the valley by measuring, cutting, bending and installing panels as precise as possible in order to create a straight line. Next step is to cut, measure and bend panels to fill in the other side of the valley. Make sure these panels meet the opposing side of the valley. The panels from the two sides of the valley should fit as close as possible from each other and the line separating them should run straight up the valley.

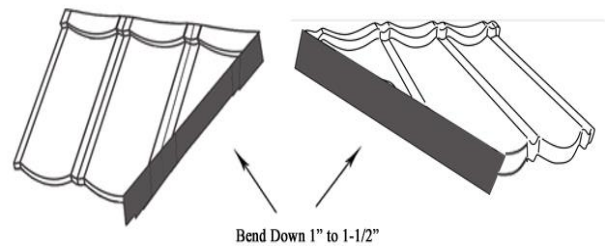
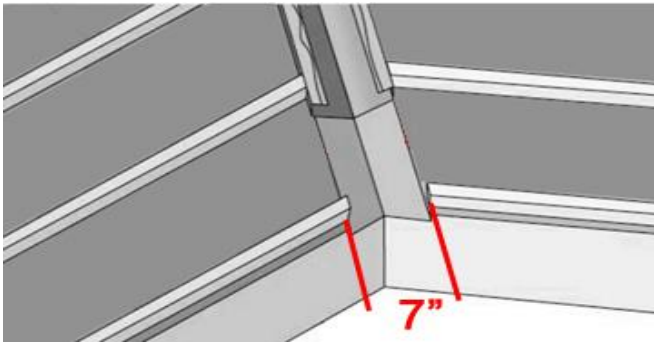

Measure and cut the tile panel to fit the 7” valley (pictured in red) and fold down 1” to 1-1/2”. Place tile panel to cover the valley. After valley flashing has been fit as close as possible and secured into the valley area and full panels have been positioned up to the valley, measure for cut panels, each illustration below shows an open or completely covered (closed) valley.

Open Valley

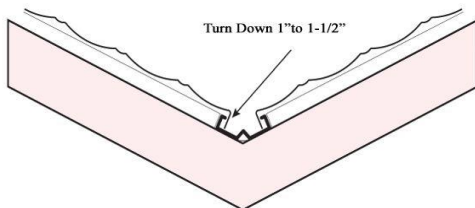

Closed Valley

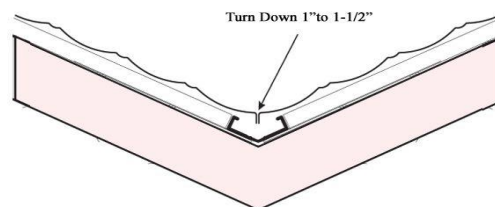

Installing Metal Tiles

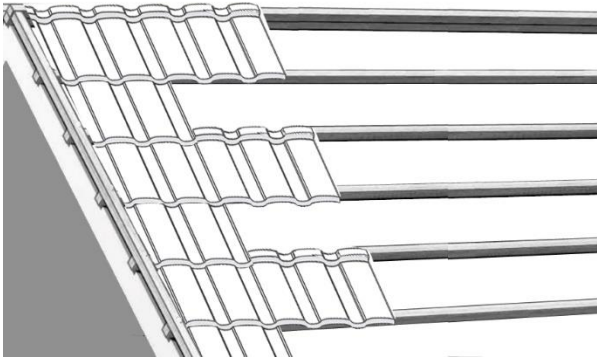

Panel Layout:

Starting from the top, place a full panel tile as the starter panel, then cut a half tile panel for the next row as pictured. The last tile panel at the top and edges should be cut and bent.

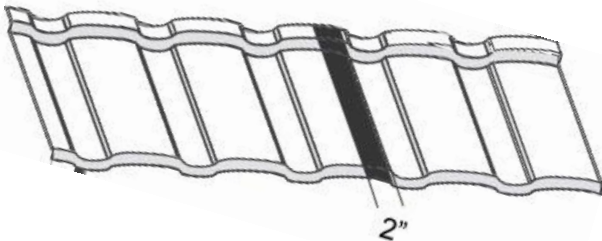

Each tile panel has a side-lap at the edge, interlock the tile panel by the side-lap and cover 2" of the connection as pictured.

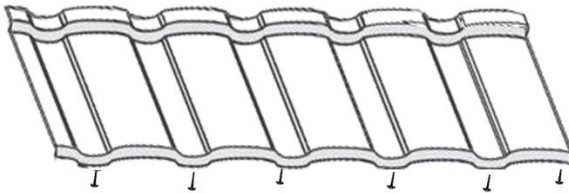

Field Condition: Fasten each panel with a minimum of 6, #8 x 1 1/2" screws at the front side, be sure to push the panels tight and fasten the panel. Panels are to be fastened to battens with approved # 8 x 1 1/2" long screws and bonded washer driven into the (lower) butt edges course and upper edge of adjoining lower course spaced 12" o.c. 6 approved screws for each full panel.

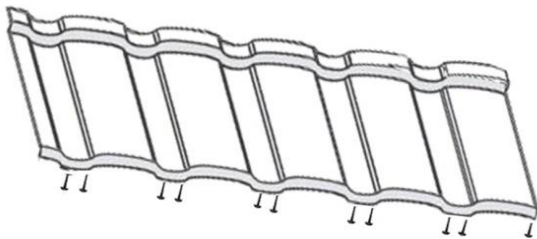

Perimeter and Corner Condition: Panels fastened to battens with approved # 8 x 1 1/2" long hex head screws # 8 x 1 1/2" long screws and bonded washer driven into the (lower) butt edges course and upper edge of adjoining lower course spaced 7" o.c. 11 approved screws for each full panel. (Page.18 High Wind Area)

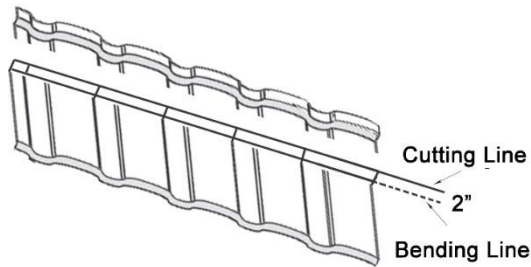

For the last tile panel on the **top**, measure and cut it to size, then fold and bend up 2” and fasten to batten.

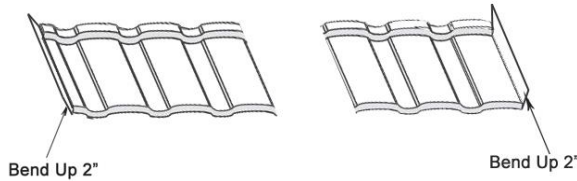

For the first and last tile panel on the left or right side, fold and bend ends up 2” and fasten to batten.

Installing Hips

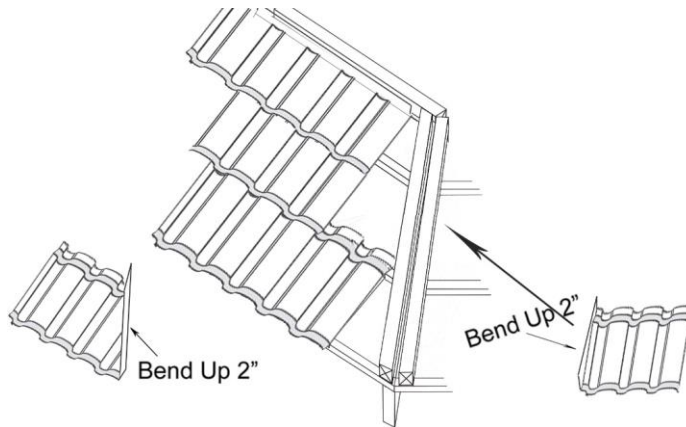

Hips:

Bring the panels to the hip, measure and cut the panels to size with a 2” excess. Bend up 2” as pictured and fasten.

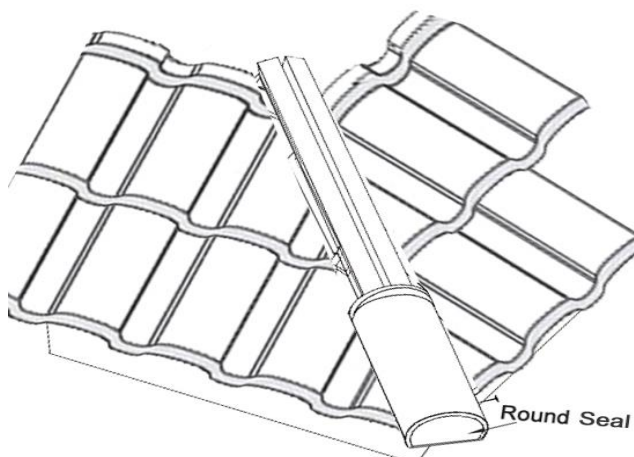

Installing Hips:

Hips should be installed starting from the bottom to the top with the upper section covering the lower section by 1” and fastened with four screws in each section as pictured.

Round Seal:

Use round seal to cover the open area at the bottom and fasten.

Installing Ridges

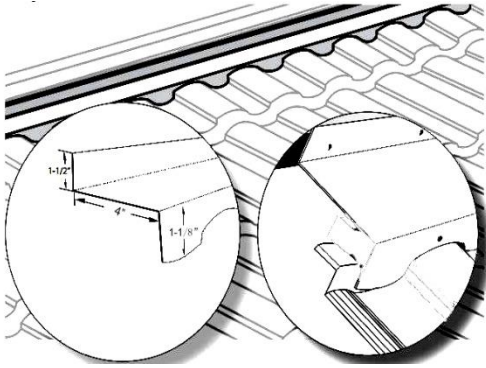

Bird Stop Top: Install the bird stop top before the ridge as pictured.

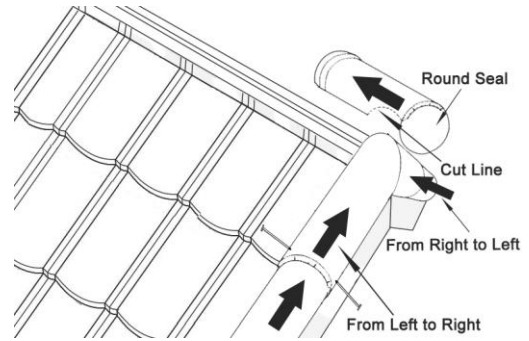

Ridges: Cut the intersecting ridge and hip along the cut line as pictured.

Installing Ridges:

Ridges should be installed starting from right to left with the left section covering the right section by 1” and fastened with four screws in each section as pictured. Measure and cut the last section to size and fasten.

Round Seal:

Use Round Seal to cover the open area at the ends and fasten.

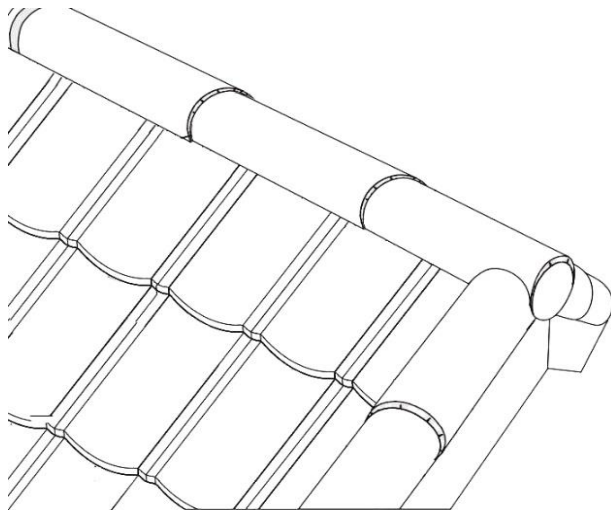
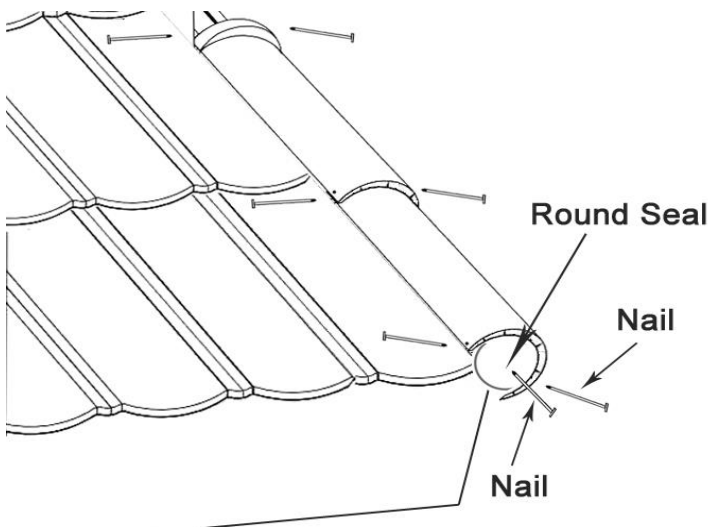

Important

Proper installation of the hips, ridges and panels should look as pictured

High Wind Area

In areas prone to hurricanes and high velocity winds, installation must meet local standards and building codes. Full panels on the top three courses and bottom three courses should be fastened with seven fasteners at seven evenly spaced locations. Also, panels along the perimeter and directly along the hips and gables must be secured at seven evenly spaced locations on the tile.

Foot Traffic

Avoid walking on side laps. Walking on tiles should be kept on the high parts and directly on battens.

Sealants

Roofing grade polyurethane sealant is recommended. Where possible, sealant should be covered by the roofing system or with matching stone granules using the touchup kit. Sealant should not be used to refinish damaged panel surfaces.

Cleaning

After installation is finished, clean off all debris off the roof and make sure any metal shavings are thoroughly removed from the roof.

Touch-up Kit

Apply the adhesive to the affected area. Sprinkle the adhesive with a generous amount of stone chips to embed them in the adhesive and allow one hour to dry. Once dry sweep any excess.



Notes: